

# PEGASUS 40.18

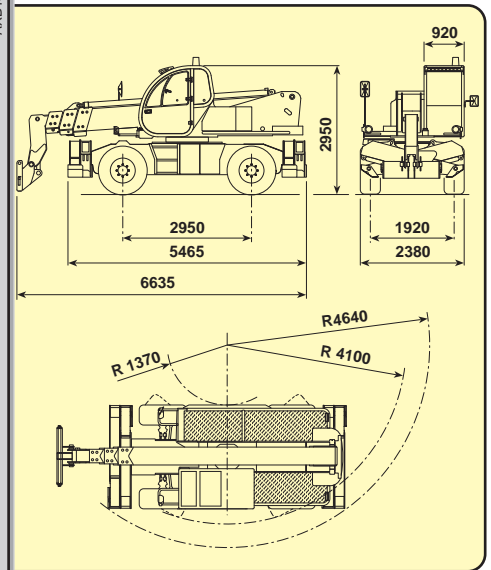

# PEGASUS 40.18

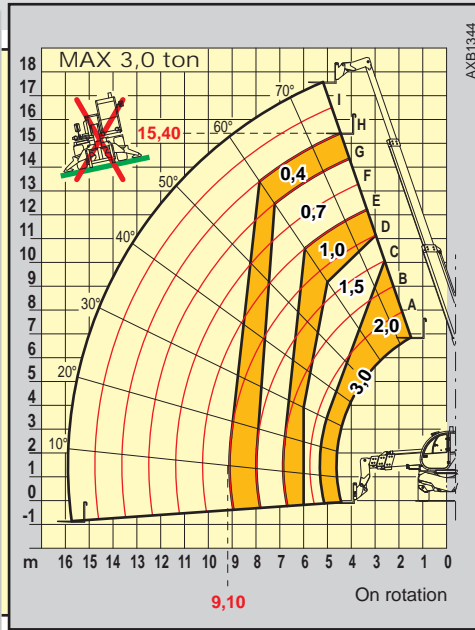
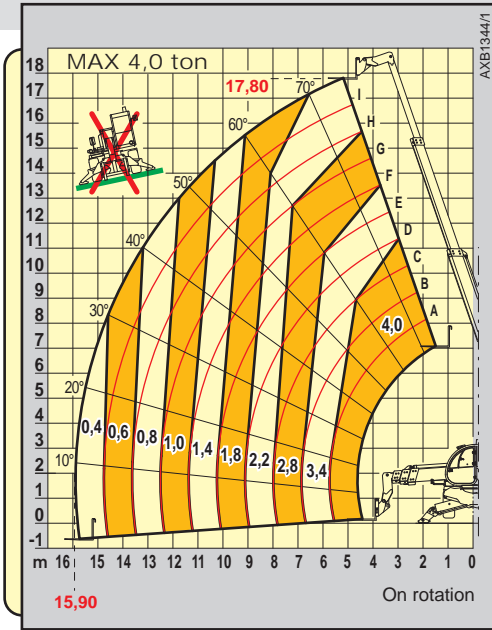

## PERFORMANCES

Maximum capacity:..... 4.000 kg  
 Capacity at maximum height on stabilizers:..... 2.200 kg  
 Capacity at maximum height on tyres:..... 400 kg  
 Maximum capacity boom on stabilizers:..... 400 kg  
 Maximum capacity boom on tyres:..... 400 kg  
 Maximum lifting height on stabilizers:..... 17,80 m  
 Maximum lifting height on tyres:..... 15,40 m  
 Maximum horizontal boom extension:..... 15,90 m  
 Boom at maximum height:..... 5,10 m  
 Angle of fork arching:..... 134°  
 Tearing force:..... 5.700 daN  
 Towing force:..... 7.300 daN  
 Maximum slope for overtaking:..... 40 %  
 Total empty weight:..... 15.800 kg  
 Max speed:..... 40 km/h



## TRANSMISSION

Transmission:..... Hydrostatic with variable capacity pump  
 Hydraulic engine:..... with automatic change  
 Gear reversing:..... Electro - hydraulic  
 Inching pedal for controlled forward movement  
 2 speed power steering.



## HYDRAULIC CIRCUIT

Gear pump with capacity at speed:..... 135 lt/1'  
 Max working pressure:..... 230 bar  
 Distributor controls with joystick:..... 5 in 1 proportional



## DIFFERENTIAL AXLES

Steering axles:..... 2, with epicycloidal reduction gears  
 Type of steering:..... 4 wheels / transversal / 2 wheels  
 Front axle:..... levelling  
 Rear axle:..... oscillating (possibility to block it)  
 Service brake:..... oil bath on 4 wheels double hydraulic circuit, parking brake

Negative parking brake.



## ENGINE

DEUTZ BF4M2012C - TA - 103 kW  
 Maximum power:..... 103 kW (141 hp) at 2500 rpm  
 Operating principle:..... four-stroke engine, diesel  
 Cylinders number and layout:..... 4, vertical in line  
 Displacement:..... 4038 cm<sup>3</sup> -Turbo compressor aftercooler  
 Cooling system:..... liquid



## REFUELLING (litre)

Hydraulic circuit:..... 243  
 Fuel tank:..... 126



## STANDARD DEVICES

Hydraulic movements with Danfoss proportional distributor.  
 Anti-tipping device with block for hazardous movements.  
 Continuous turret rotation over 360°.  
 Oscillation block on rear axle.  
 Hydraulic socket for possible accessories on boom head.  
 Closed soundproof homologated cab FOPS, with heating.  
 Stabilizers.



## TYRES

Tyres:..... 19,5"



## OPTIONAL AND ACCESSORIES

Optional and Accessories:..... see the relevant catalogue.

The information contained in the present publication are only intended as an indication; the models described may be modified, without notice, by the manufacturer, drawings and photographs may refer to optional equipment or to particular specifications for other countries. For any further information, please contact DIECI headquarters at the address given below. (Cod. SKT AXE3060: SCHEDA TECNICA - PEGASUS 40.18 - INGLESE 06/2004 v1)